

SJ3013 micro ELECTRIC SCISSOR



STANDARD FEATURES

- Drivable at full height
- Variable speed, rear wheel electric drive
- Dual holding brakes
- Upper control box with integrated steel shroud
- Tilt Sensor (3.5° x 2.5°)
- 20" (0.51 m) Roll out extension deck
- 24V DC power source
- Low voltage battery protection
- 25% Gradeability
- Solid rubber, non-marking tires
- Pothole protection system
- Tilt alarm with drive & lift cut-out
- Lowering alarm
- Lanyard attachment points
- Operator horn
- Forklift pockets and tie down/lift lugs
- Overload sensing system
- Fold down hinged railing system
- Overall machine height under 80" (stowed)
- Maintenance free Gel batteries
- Flashing lights
- Locking battery tray
- Pull-out tray for easy access
- Hydraulic oil level indicator
- Battery level indicator

OPTIONS ‡

- ECOTRAY leak containment system
- Telematics

‡ Standard lead times may be increased when optional equipment is added, consult factory.
Capacities and machine weights may differ when options are added.

SJ3013 micro ELECTRIC SCISSOR

Dimensions	Imperial	Metric
A Work Height	19'	5.79 m
B Raised Platform Height	13'	3.96 m
C Overall Width	30"	0.76 m
D Overall Length	59"	1.49 m
E Stowed Height (Rails Up)	79.5"	2.02 m
F Stowed Height (Rails Down)	63"	1.59 m
G Platform Width (Inside Dimension)	30"	0.76 m
H Platform Length (Inside Dimension)	50"	1.28 m
Specifications		
Extension Deck (Roll Out)	20"	0.51 m
Ground Clearance (Pothole Raised)	2.4"	6 cm
Wheelbase	41"	1.05 m
Weight	2095 lbs	950 kg
Gradeability	25%	
Turning Radius (Inside)	14"	0.35 m
Lift Time (With Rated Load)	25 sec	
Lower time (With Rated Load)	18 sec	
Drive Speed (Stowed)	1.9 mph	3.0 km/h
Drive Speed (Raised)	0.5 mph	0.8 km/h
Maximum Drive Height	Full Height	
Capacity (Overall)	500 lbs	227 kg
Distributed Capacity (Extension Deck)	220 lbs	100 kg
Local Floor Load (With Rated Load)	82 psi	565 kPa
Overall Floor Load (With Rated Load)	271 psf	1322 kg/m ²
Maximum # of persons at 0 mph (0 m/s) wind rating	2	
Maximum # of persons up to 28 mph (12.5 m/s) wind rating	1	
Tire Type	Solid rubber, N/M	
Tire Size	9 x 3	

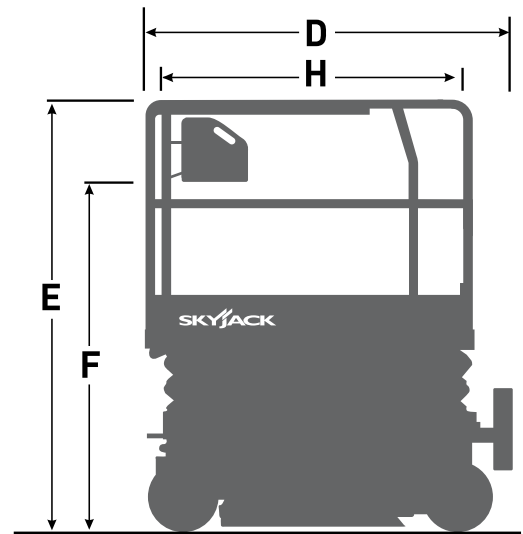
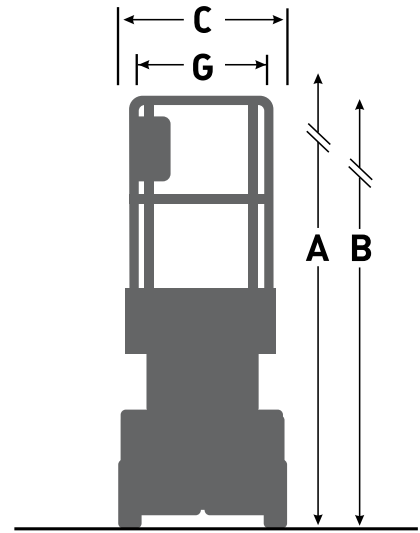

Skyjack Head Office
 55 Campbell Rd. Guelph, ON Canada N1H 1B9
 Sales Inquiries: 1-877-755-4387 (1-877-SJLIFTS)
 Main Switchboard: 1-800-265-2738
 Phone: 519-837-0888
 Fax: 519-837-8104
 Email: skyjack@skyjack.com

www.skyjack.com

SKYJACK
 simply reliable