

SJ63 AJ+

ARTICULATING BOOM



STANDARD FEATURES

- EASYDRIVE™ Direction sensing drive and steer controls
- SPEEDYREACH™ Negative boom angle capability
- SKYRISER™ True vertical rise
- AXLDRIIVE™ Axle-based 4WD system
- Operator controlled locking rear differential and limited slip front differential
- Oscillating steer axle
- Drivable at full height
- 45% Gradeability
- Wet disc SAHR brakes (front and rear axle)
- Dual module control system with SKYCODED™ color coded and numbered wiring
- Deutz TD2.9L4 diesel or Kubota WG2503 dual fuel engine
- Swing out engine tray
- Swing up cowlings for easy access
- Lockable power disconnect switch
- Proportional controls
- 660/1,000 lbs (300/454 kg) Dual capacity
- 36" x 96" Platform
- Bolt-in platform railing system
- Lanyard attachment points
- Tri-entry sliding mid-rails
- Secondary Guarding Electrical (SGE)
- Overload sensing system
- 110V AC Outlet on platform with GFI
- Tilt alarm (5.0° x 5.0°) with drive and lift cut-out
- Single point emergency lowering
- Hourmeter
- Operator horn
- All motion alarm
- 360° Continuous turret rotation
- Tie down / lifting lugs
- 14 x 17.5 Grip lug foam-filled tires
- Telematics ready
- 2-Year Gold Leaf Warranty (5-year structural warranty)

OPTIONS

- Glazier kit
- Pipe rack
- Tool caddy
- Flashing light
- 36" x 72" Platform
- Side spring hinged entry gate
- Auxiliary top rail (36 x 96" platform only)
- 3.5 kW Generator (includes hydraulic oil cooler)
- Welder ready package (includes 12 kW generator, hydraulic oil cooler, 3 phase power connection in platform, and welder mount.)
- Welder package (includes 12 kW generator, hydraulic oil cooler, 3 phase power connection in platform, welder mount and Lincoln V275-S welder)
- Cold weather start kit (Recommended for regions where average monthly low temperatures can reach 14°F / -10°C (Includes cold start engine oil, battery blanket, hydraulic tank heater, and engine load kit (Deutz TD2.9L4))
- Arctic weather package (Recommended for regions where average monthly low temperatures can reach -0.4°F / -18°C (Includes arctic engine oil, battery blanket, hydraulic tank heater, engine load kit (Deutz TD2.9L4), block heater, arctic hydraulic oil, arctic platform rotator and arctic gear oil in the axles and swing drive glow plugs, arctic hydraulic hoses (all), and oversized foot switch cover are also included (standard equipment))
- Extra propane tank and bracket (dual fuel only)
- Positive air shut-off valve (diesel only)
- Hydraulic oil cooler
- Bio oil
- Hostile environment package (Includes cylinder bellows, boom wipers, covers for the fly boom cutouts, and control box cover)
- Control box cover
- Grip lug non-marking foam-filled tires
- Non-destructive testing
- ELEVATE telematics

† Standard lead times may be increased when optional equipment is added, consult factory.
‡ Capacities and machine weights may differ when options are added.

SJ63 AJ+ ARTICULATING BOOM

Dimensions	SJ63 AJ+
Work Height	69' 3" (21.11 m)
Platform Height	63' 3" (19.28 m)
Horizontal Reach	39' 9" (12.12 m)
Up and Over Height	27' 6" (8.38 m)
A Platform Size	36" x 96" (0.91 x 2.44 m)
B Stowed Width	8' (2.44 m)
C Tailswing	0
D Stowed Height	8' 4" (2.54 m)
E Transportation Height	9' 2" (2.79 m)
F Stowed Length	30' (9.14 m)
G Transportation Length	25' 5" (7.75 m)
H Wheelbase	8' (2.44 m)
I Ground Clearance	13" (0.33 m)
Specifications	SJ63 AJ+
Rotation	360° Continuous
Platform Rotation	170°
Jib Length	5' (1.52 m)
Jib Range +/-	+65° / -60°
Weight	22,560 lbs (10,235 kg)
Gradeability	45%
Turning Radius (Inside)	7' 3" (2.21 m)
Turning Radius (Outside)	17' 5" (5.31 m)
Axle Oscillation	4" (10.16 m)
Drive Speed (High speed)	4.5 mph (7.2 km/h)
Capacity	660 / 1,000 lbs (300 / 454 kg)
Maximum Wind Speed	28 mph (12.5 m/s)
Personnel Rating at Max Wind Rating	2 / 3
Tire Type	Foam-Filled
Tire Size	14 x 17.5
Diesel Engine	Deutz TD2.9L - 74 HP (55 KW)
Dual Fuel Engine	Kubota WG2503 - 61 HP (45 KW)
Fuel Tank Capacity	30.4 gal. (115L)
Hydraulic Reservoir	30.4 gal. (115L)

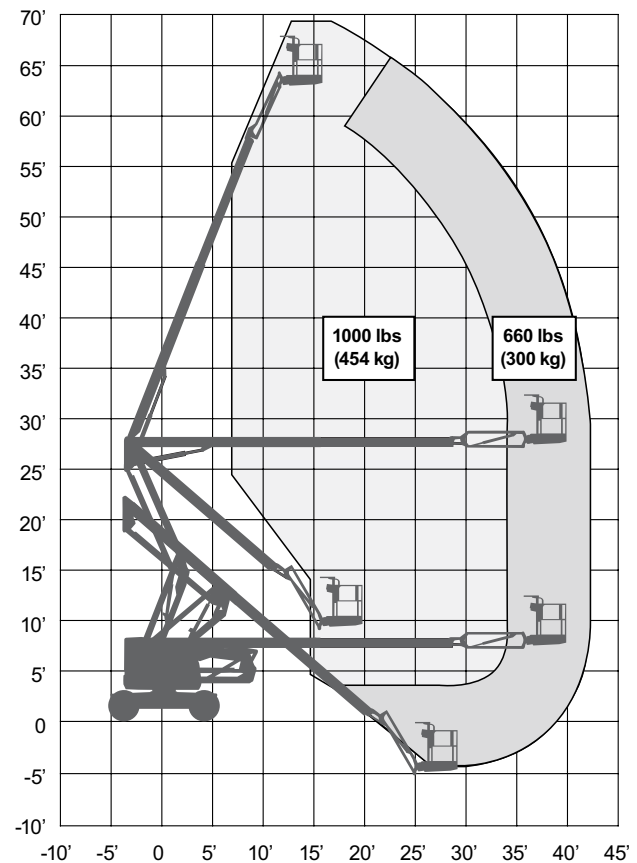
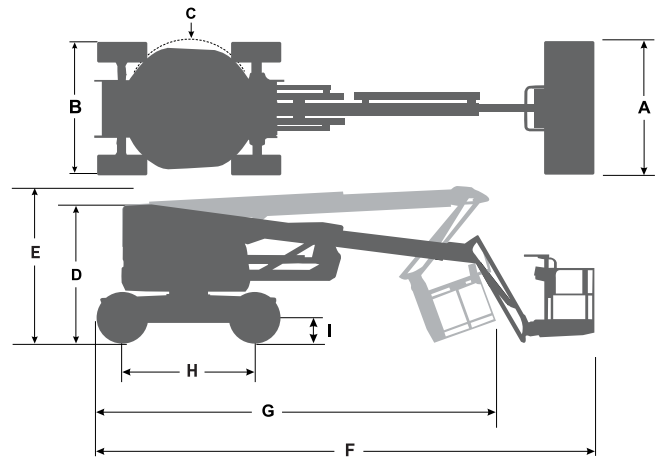

SJ63 AJ+ WORKING ENVELOPE

Skyjack Head Office
 55 Campbell Rd. Guelph, ON Canada N1H 1B9
 Sales Inquiries: 1-877-755-4387 (1-877-SJLIFTS)
 Main Switchboard: 1-800-265-2738
 Phone: 519-837-0888
 Fax: 519-837-8104
 Email: skyjack@skyjack.com

www.skyjack.com

SKYJACK
 simply reliable