

SJ4726/32

ELECTRIC SCISSORS



STANDARD FEATURES

- Drivable at full height
- Variable speed, rear two wheel hydraulic drive
- Dual holding brakes
- SKYCODED™ Color coded and numbered wiring system
- On-board visual interface with diagnostic capabilities
- Shroud style, impact resistant composite control box with extended cable
- Proportional controls for drive & lift functions
- Tilt sensor (3.5° x 1.5°)
- 4' (1.22 m) Roll out extension deck
- 24V DC Power source
- Low voltage battery protection
- 25% Gradeability
- Solid rubber, non-marking tires
- Pothole protection system
- 110V AC Outlet on platform with GFI
- 28 mph (12.5 m/s) Wind rating
- Tilt alarm with drive & lift cut-out
- All motion audible alarm
- Lanyard attachment points
- Operator horn
- Forklift pockets and tie down/lift lugs
- Overload sensing system
- Fold down hinged railing system
- Half height spring hinged entry gate
- Telematics ready
- 2-Year Gold Leaf Warranty (5-year structural warranty)

OPTIONS

- Light duty pipe rack
- Heavy duty pipe rack
- Board carrier
- Tool caddy
- Flashing light
- Dual flashing lights
- 6' (1.83 m) Powered ext. deck (SJ4726)[†]
[†]adds 251 lbs (114 kg) to unit weight and capacity remains the same
- 800W AC Inverter
- 250 Ah Batteries (cannot be combined with EE rating package)
- AGM Batteries
- Lockable swingout trays
- EE Rating package (not available with telematics keypad)
- Aircraft protection package (SJ4726 only)
- Full height spring hinged entry gate
- Bio oil
- Secondary Guarding Lift Enable (SGLE)
- Non-destructive testing
- ECOTRAY leak containment system

[†] Standard lead times may be increased when optional equipment is added, consult factory.
[‡] Capacities and machine weights may differ when options are added.

SJ4726/32 ELECTRIC SCISSOR LIFTS

Dimensions	SJ4726	SJ4732
A Work Height	31' 8" (9.65 m)	37' 8" (11.48 m)
B Raised Platform Height	25' 8" (7.82 m)	31' 8" (9.65 m)
C Lowered Platform Height	46" (1.17 m)	50" (1.27 m)
D Overall Width	47" (1.19 m)	47" (1.19 m)
E Overall Length	91.6" (2.32 m)	91.6" (2.32 m)
F Stowed Height (Rails Up)	90" (2.29 m)	94" (2.39 m)
G Stowed Height (Rails Down)	75" (1.90 m)	78.5" (1.99 m)
H Platform Width (Inside Dimension)	42" (1.07 m)	42" (1.07 m)
I Platform Length (Inside Dimension)	83" (2.11 m)	83" (2.11 m)
Specifications	SJ4726	SJ4732
Extension Deck (Roll Out)	4' (1.22 m)	4' (1.22 m)
Ground Clearance (Pothole Raised)	4.0" (10.2 cm)	4.0" (10.2 cm)
Ground Clearance (Pothole Deployed)	0.5" (1.3 cm)	0.5" (1.3 cm)
Wheelbase	69" (1.75 m)	69" (1.75 m)
Weight	5,537 lbs (2,511 kg)	5,496 lbs (2,492 kg)
Gradeability	25%	25%
Turning Radius (Inside)	28" (0.71 m)	28" (0.71 m)
Turning Radius (Outside)	104" (2.64 m)	104" (2.64 m)
Lift Time (With Rated Load)	52 sec	50 sec
Lower time (With Rated Load)	32 sec	30 sec
Drive Speed (Stowed)	2.0 mph (3.2 km/h)	2.0 mph (3.2 km/h)
Drive Speed (Raised)	0.6 mph (1.0 km/h)	0.6 mph (1.0 km/h)
Maximum Drive Height	Full Height	Full Height
Capacity (Overall)	1,000 lbs (454 kg)	700 lbs (318 kg)
Distributed Capacity (Main Platform)	700 lbs (318 kg)	450 lbs (204 kg)
Distributed Capacity (Extension Deck)	300 lbs (136 kg)	250 lbs (113 kg)
Local Floor Load (With Rated Load)	131 psi (903 kPa)	124 psi (856 kPa)
Overall Floor Load (With Rated Load)	234 psf (1,143 kg/m ²)	222 psf (1,083 kg/m ²)
Maximum # of persons at 0 mph (0 m/s) wind rating	3	2
Maximum # of persons up to 28 mph (12.5 m/s) wind rating	2	1
Tire Type	Solid, N/M	Solid, N/M
Tire Size	16 x 5 x 12	16 x 5 x 12

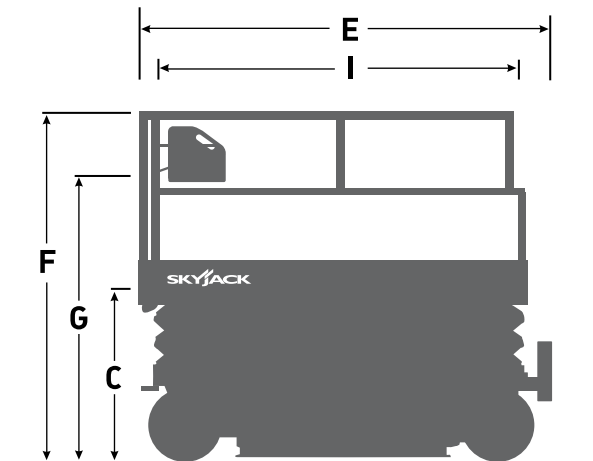
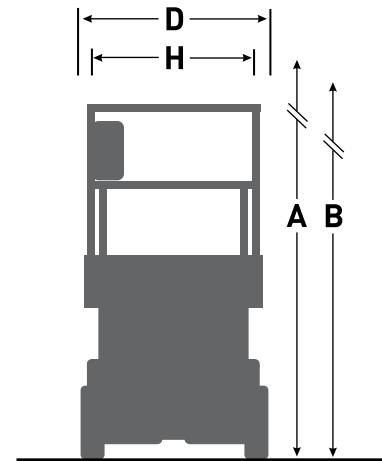

Skyjack Asia

Room 608 Building 46, No.555 Guiping Road
Xuhui District, Shanghai City PRC, 200233
Tel: +86 21 63128387
Email: asia.sales@skyjack.com

Skyjack Head Office

55 Campbell Road, Guelph, ON Canada N1H 1B9
Sales Inquiries: 1-877-755-4387 (1-877-SJLIFTS)
Main Switchboard: 1-800-265-273

www.skyjack.com



SKYJACK
simply reliable