

SJ4740

ELECTRIC SCISSORS



STANDARD FEATURES

- Drivable at full height
- Variable speed, front wheel hydraulic drive
- Dual holding brakes
- SKYCODED™ Color coded and numbered wiring system
- On-board visual interface with diagnostic capabilities
- Shroud style, impact resistant composite control box with extended cable
- Proportional controls for drive & lift functions
- Tilt Sensor (3.5° x 1.5°)
- 3' (0.91 m) Roll out extension deck
- 24V DC Power source
- Low voltage battery protection
- 25% Gradeability
- Solid rubber, non-marking tires
- Pothole protection system
- 110V AC Outlet on platform with GFI
- 28 mph (12.5 m/s) wind rating to 24' (7.32 m)
- Tilt alarm with drive & lift cut-out
- All motion audible alarm
- Lanyard attachment points
- Operator horn
- Forklift pockets and tie down/lift lugs
- Overload sensing system
- Fold down hinged railing system
- Half height spring hinged entry gate
- Telematics ready
- 2-Year Gold Leaf Warranty (5-year structural warranty)

OPTIONS

- Light duty pipe rack
- Heavy duty pipe rack
- Board carrier
- Tool caddy
- Flashing light
- Dual flashing lights
- 800W AC Inverter
- AGM Batteries
- Lockable swingout trays
- Full height spring hinged entry gate
- Bio oil
- Secondary Guarding Lift Enable (SGLE)
- Non-destructive testing
- ECOTRAY leak containment system

† Standard lead times may be increased when optional equipment is added, consult factory.
‡ Capacities and machine weights may differ when options are added.

SJ4740 ELECTRIC SCISSOR LIFT

Dimensions	SJ4740
A Work Height	44' 11" (13.69 m)
B Raised Platform Height	38' 11" (11.86 m)
C Lowered Platform Height	56" (1.41 m)
D Overall Width	47" (1.20 m)
E Overall Length (Platform Retracted)	94.5" (2.40 m)
F Stowed Height (Rails Up)	99.5" (2.53 m)
G Stowed Height (Rails Down)	79.5" (2.03 m)
H Platform Width (Inside Railing)	42" (1.06 m)
I Platform Inside Length (Retracted)	86" (2.19 m)
Specifications	SJ4740
Extension Deck (Roll Out)	3' (0.91 m)
Ground Clearance (Pothole Raised)	4.5" (11.4 cm)
Ground Clearance (Pothole Deployed)	0.5" (1.3 cm)
Wheelbase	73" (1.85 m)
Weight	6,467 lbs (2,934 kg)
Gradeability	25%
Turning Radius (Inside)	17.5" (0.45 m)
Turning Radius (Outside)	99" (2.51 m)
Lift Time (With Rated Load)	68 sec
Lowered Time (With Rated Load)	41 sec
Drive Speed (Stowed)	1.9 mph (3.0 km/h)
Drive Speed (Raised)	0.5 mph (0.8 km/h)
Maximum Drive Height	Full Height
Capacity (Overall)	770 lbs (349 kg)
Distributed Capacity (Main Platform)	505 lbs (229 kg)
Distributed Capacity (Extension Deck)	265 lbs (120 kg)
Local Floor Load (With Rated Load)	139 psi (956 kPa)
Overall Floor Load (With Rated Load)	233 psf (1,137 kg/m ²)
Maximum # of persons at 0 mph (0 m/s) wind rating	3
Maximum # of persons up to 28 mph (12.5 m/s) wind rating	1 up to 24' (7.32 m)
Tire Type	Solid, N/M
Tire Size	16 x 5 x 12

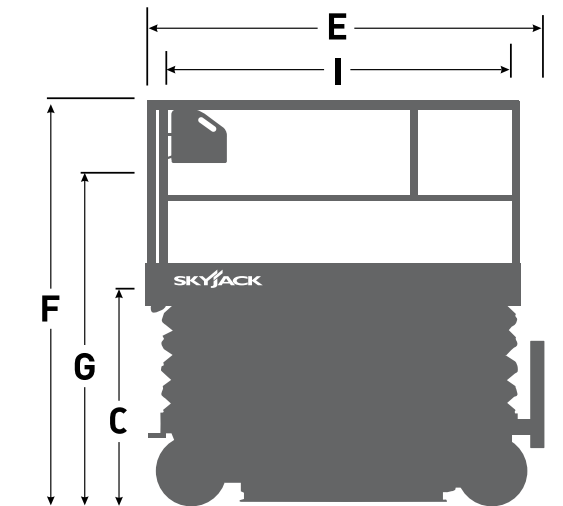
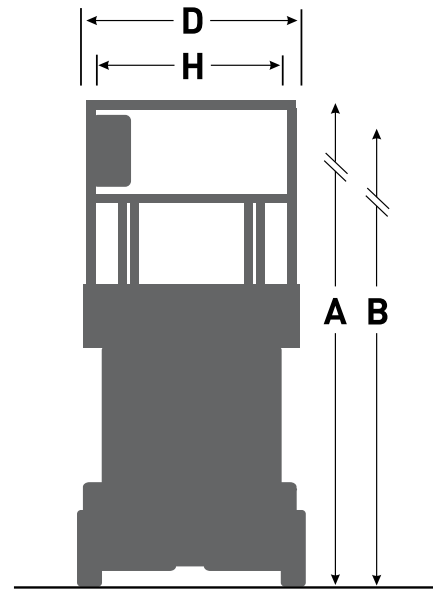

Skyjack Asia

Room 608 Building 46, No.555 Guiping Road
Xuhui District, Shanghai City PRC, 200233
Tel: +86 21 63128387
Email: asia.sales@skyjack.com

Skyjack Head Office

55 Campbell Road, Guelph, ON Canada N1H 1B9
Sales Inquiries: 1-877-755-4387 (1-877-SJLIFTS)
Main Switchboard: 1-800-265-273

www.skyjack.com



SKYJACK
simply reliable