



SJ60 AJ+

ARTICULATING BOOMS



STANDARD FEATURES

- EASYDRIVE™ Direction sensing drive and steer controls
- SPEEDYREACH™ Negative boom angle capability
- SKYRISER™ True vertical rise
- AXLDRIIVE™ Axle-based 4WD system
- Operator controlled locking rear differential and limited slip front differential
- Oscillating steer axle
- Drivable at full height
- 40% Gradeability
- Wet disc SAHR brakes (front and rear axle)
- Dual module control system with SKYCODED™ color coded and numbered wiring
- Kubota D1305 Tier 4F diesel engine
- Swing up cowlings for easy access
- Lockable power disconnect switch
- Proportional controls
- 660 / 1,000 lbs Dual Capacity
- 36 x 96" Platform
- Bolt-in platform railing system
- Lanyard attachment points
- Tri-entry sliding mid rails
- Secondary Guarding Electrical (SGE)
- Overload sensing system
- 110V AC Outlet on platform with GFI
- Tilt alarm (5.0° x 5.0°) with drive and lift cut-out
- Single point emergency lowering
- Hourmeter
- Operator horn
- All motion alarm
- 360° Continuous turret rotation
- Tie down/lifting lugs
- Grip lug foam-filled tires
- Telematics ready
- 2 Year Gold Leaf Warranty (5 year structural warranty)



- Over 20% carbon saving compared to previous model



- 15% weight reduction
- Truck based fuel savings



- 3% reduction in engine noise (excl. alarms)
- White noise alarm – optional



- 90% recyclable (by weight)
- Bio-degradeable oil – Environmentally friendly and reduced clean-up costs – optional



- Up to 65% less fuel used compared to engine used in previous model
- Emission compliant – Tier 4F
- HVO compatible – Up to 85% CO2 & NOX saving compared to diesel

† Standard lead times may be increased when optional equipment is added, consult factory.
‡ Capacities and machine weights may differ when options are added.

SJ60 AJ+ ARTICULATING BOOMS

Dimensions	SJ60 AJ+
Work Height	66' (20.11 m)
Platform Height	60' (18.29 m)
Horizontal Reach	37' 11" (11.56 m)
Up and Over Height	27' 2" (8.31 m)
A Platform Size	36" x 96" (0.91 x 2.44 m)
B Stowed Width	8' (2.44 m)
C Tailswing	2' (0.61 m)
D Stowed Height	8' 4" (2.54 m)
E Transportation Height	9' 2" (2.79 m)
F Stowed Length	28' 2" (8.59 m)
G Transportation Length	21' 8" (6.60 m)
H Wheelbase	8' (2.44 m)
I Ground Clearance	13" (0.33 m)

Specifications	SJ60 AJ+
Rotation	360° Continuous
Platform Rotation	170°
Jib Length	5' (1.52 m)
Jib Range +/-	+65° / -60°
Weight	18,865 lbs (8,557 kg)
Gradeability	40%
Turning Radius (Inside)	7' 3" (2.21 m)
Turning Radius (Outside)	17' 5" (5.31 m)
Axle Oscillation	4" (10.16 cm)
Drive Speed (High speed)	2.5 mph (4.0 km/h)
Capacity	660 / 1,000 lbs (300 / 454 kg)
Maximum Wind Speed	28 mph (12.5 m/s)
Personnel Rating at Max Wind Rating	2 / 3
Tire Type	Foam-Filled
Tire Size	14 x 610
Diesel Engine	Kubota D1305 - 24.8 HP (18.5 KW)
Fuel Tank Capacity	30.4 gal. (115L)
Hydraulic Reservoir	30.4 gal. (115L)

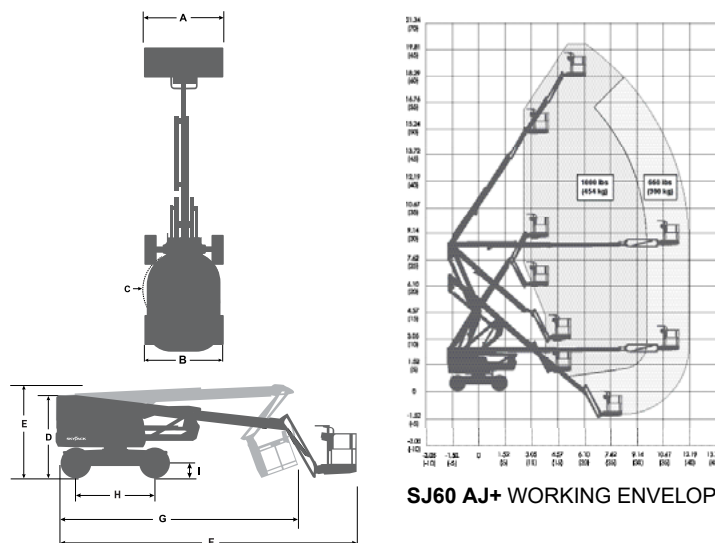

SJ60 AJ+ WORKING ENVELOPE

ACCESSORIES

- Pipe rack
- Glazier kit
- Tool caddy

OPTIONS

- Kubota WG972 dual fuel engine
- Extra propane tank and bracket (dual fuel only)
- Flashing light
- 36 x 72" Platform
- Side spring hinged entry gate
- Auxiliary top rail (36 x 96" platform only)
- 3.5 kW generator
- Welder ready package
(Includes 7.5 kW generator, 3-phase power connection in platform, and welder mount)
- Welder package
(Includes 7.5 kW generator, 3-phase power connection in platform, welder mount, and Lincoln V275-S welder)
- Cold weather start kit*
*Recommended for regions where average monthly low temperatures can reach 14°F / -10°C (Includes cold start engine oil, battery blanket, and hydraulic tank heater)
- Arctic weather package*
*Recommended for regions where average monthly low temperatures can reach -0.4°F / -18°C (Includes arctic engine oil, battery blanket, hydraulic tank heater, block heater, arctic hydraulic oil, and arctic gear oil in the axles and swing drive. Glow plugs, arctic hydraulic hoses (all), arctic platform rotator and oversized foot switch cover are also included (standard equipment).)
- Control box cover
- Diesel scrubber for tier 4 final engine
- Positive air shut-off valve (diesel only)
- Bio oil
- Non destructive testing
- Grip lug foam-filled non marking tires



Skyjack Asia
Room 608 Building 46, No.555 Guiping Road
Xuhui District, Shanghai City PRC, 200233
Tel: +86 21 63128387
Email: asia.sales@skyjack.com

Skyjack Head Office
55 Campbell Road, Guelph, ON Canada N1H 1B9
Sales Inquiries: 1-877-755-4387 (1-877-SJLIFTS)
Main Switchboard: 1-800-265-273

www.skyjack.com

SKYJACK
simply reliable