

SJ61/66 T+

TELESCOPIC BOOMS



STANDARD FEATURES

- EASYDRIVE™ Direction sensing drive and steer controls
- AXLDRIVE™ Axle-based 4WD system
- Operator controlled locking rear differential and limited slip front differential
- Oscillating steer axle
- Drivable at full height
- 50% Gradeability
- Wet disc SAHR brakes (front and rear axle)
- Dual module control system with SKYCODED™ color coded and numbered wiring
- Deutz TD2.9L4 diesel or Kubota WG2503 dual fuel engine
- Swing out engine tray
- Swing up cowlings for easy access
- Lockable power disconnect switch
- Proportional controls
- 660/1,000 lbs (300/454 kg) Dual capacity
- 36" x 96" Platform
- Bolt-in platform railing system
- Lanyard attachment points
- Tri-entry sliding mid rails
- Secondary Guarding Electrical (SGE)
- Overload sensing system
- 110V AC Outlet on platform with GFI
- Tilt alarm (5.0° x 5.0°) with drive and lift cut-out
- Single point emergency lowering
- Hourmeter
- Operator horn
- All motion alarm
- 360° Continuous turret rotation
- Tie down / lifting lugs
- 15 x 19.5 Grip lug foam-filled tires
- Telematics ready
- 2-Year Gold Leaf Warranty (5-year structural warranty)

OPTIONS

- Glazier kit
- Pipe rack
- Tool caddy
- Flashing light
- 36" x 72" Platform
- Side spring hinged entry gate
- Auxiliary top rail (36 x 96" platform only)
- 3.5 kW Generator (Includes hydraulic oil cooler)
- Welder ready package (Includes 12 kW generator, hydraulic oil cooler, 3-phase power connection in platform, and welder mount)
- Welder package (Includes 12 kW generator, hydraulic oil cooler, 3-phase power connection in platform, welder mount, and Lincoln V275-S welder)
- Cold weather start kit (Recommended for regions where average monthly low temperatures can reach 14°F / -10°C (Includes cold start engine oil, battery blanket, hydraulic tank heater, and engine load kit (Deutz TD2.9L4))
- Arctic weather package (Recommended for regions where average monthly low temperatures can reach -0.4°F / -18°C (Includes arctic engine oil, battery blanket, hydraulic tank heater, engine load kit (Deutz TD2.9L4), block heater, arctic hydraulic oil, arctic platform rotator and arctic gear oil in the axles and swing drive glow plugs, arctic hydraulic hoses (all), and oversized foot switch cover are also included (standard equipment).)
- Positive air shut-off valve (diesel only)
- Hydraulic oil cooler
- Bio oil
- Control box cover
- Grip lug foam-filled non-marking tires
- Non-destructive testing

† Standard lead times may be increased when optional equipment is added, consult factory.
‡ Capacities and machine weights may differ when options are added.

SJ61/66 T+ TELESCOPIC BOOMS

Dimensions	SJ61 T+	SJ66 T+
Work Height	67' 8" (20.62 m)	72' 3" (22.02 m)
Platform Height	61' 8" (18.80 m)	66' 3" (20.19 m)
Horizontal Reach	51' 3" (15.62 m)	57' 0.25" (17.38 m)
A Platform Size	36" x 96" (0.91 x 2.44 m)	36" x 96" (0.91 x 2.44 m)
B Stowed Width	8' (2.44 m)	8' (2.44 m)
C Tailswing	4' 4" (1.33 m)	4' 4" (1.33 m)
D Stowed Height	8' 6" (2.59 m)	8' 6" (2.59 m)
E Transportation Height	-	10' 10" (3.30 m)
F Stowed Length	30' 3.75" (9.24 m)	34' 1.5" (10.40 m)
G Transportation Length	-	26' 8" (8.13 m)
H Wheelbase	8' (2.44 m)	8' (2.44 m)
I Ground Clearance	14.25" (0.36 m)	14.25" (0.36 m)
Specifications	SJ61 T+	SJ66 T+
Rotation	360° Continuous	
Platform Rotation	170°	170°
Jib Length	-	5' (1.52 m)
Jib Range +/-	-	+65° / -60°
Weight	25,050 lbs (11,365 kg)	27,745 lbs (12,585 kg)
Gradeability	50%	50%
Turning Radius (Inside)	6' 4" (1.93 m)	6' 4" (1.93 m)
Turning Radius (Outside)	16' 7" (5.05 m)	16' 7" (5.05 m)
Axle Oscillation	3.5" (8.89 cm)	3.5" (8.89 cm)
Drive Speed (High speed)	4.5 mph (7.2 km/h)	4.5 mph (7.2 km/h)
Capacity	660/1000 lbs (300/454 kg)	660/1000 lbs (300/454 kg)
Maximum Wind Rating	28 mph (12.5 m/s)	28 mph (12.5 m/s)
Personnel Rating at Max Wind Rating	2 / 3	2 / 3
Tire Type	Foam-Filled	Foam-Filled
Tire Size	15 x 19.5	15 x 19.5
Diesel Engine	Deutz TD2.9L - 74 HP (55 KW)	
Duel Fuel Engine	Kubota WG2503 - 61 HP (45 KW)	
Fuel Tank Capacity	45 gal. (170 L)	
Hydraulic Reservoir	60 gal. (227 L)	

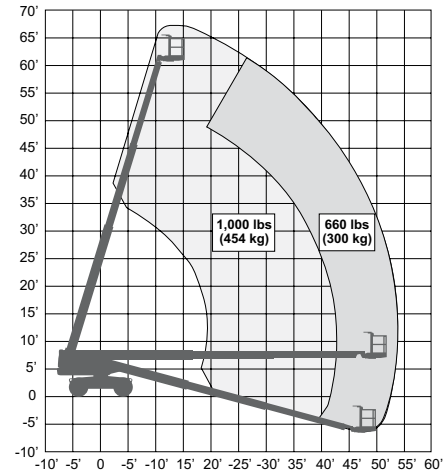
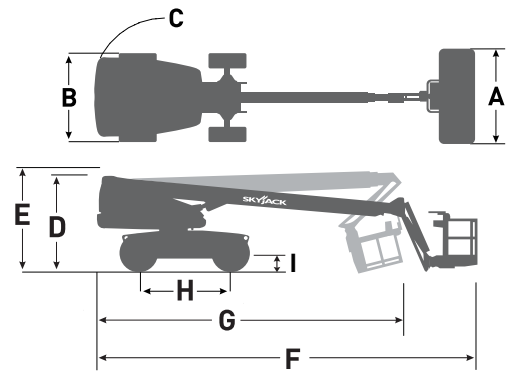

SJ61 T+ WORKING ENVELOPE

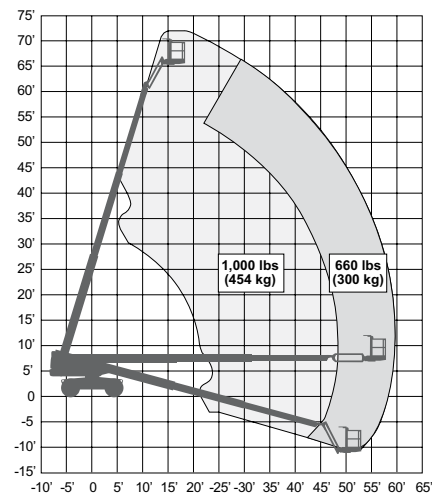

SJ66 T+ WORKING ENVELOPE

Skyjack Asia

Room 608 Building 46, No.555 Guiping Road
Xuhui District, Shanghai City PRC, 200233
Tel: +86 21 63128387
Email: asia.sales@skyjack.com

Skyjack Head Office

55 Campbell Road, Guelph, ON Canada N1H 1B9
Sales Inquiries: 1-877-755-4387 (1-877-SJLIFTS)
Main Switchboard: 1-800-265-273

www.skyjack.com



SKYJACK
simply reliable